

**NEW**

**Energy Performance roof hatch**  
**The highest insulation value in the market**



**Innovation in Roof Access ...**

## Gorter Roof Hatches

- » Energy saving
- » Construction with thermal break technology
- » Can be supplied complete with safety hook on ladder, scissor stair or fixed stair/ladder
- » Available sizes: 700 x 1400 mm and 1000 x 1500 mm

Extremely high insulation:  $U_w \leq 0.198 \text{ W}/(\text{m}^2.\text{K})$   
for the entire roof hatch construction

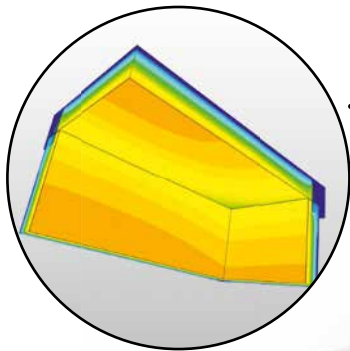

One hand operation



Insulated curb

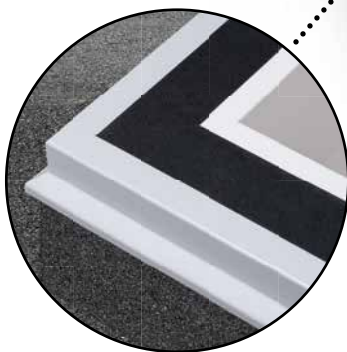

Thermally insulated cover

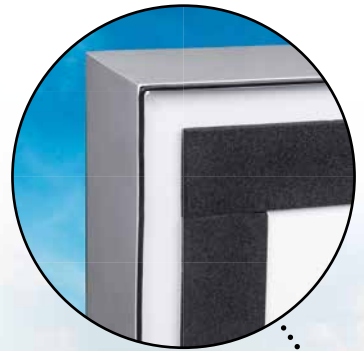

Stainless steel safety cylinder with  
indoor and outdoor operation



Handrail for safe access and exit



Opening assistance and fall-back brake



Wind- and watertight sealing all around



Burglar-proof stainless steel hinges



Simple installation with stainless insertion tabs

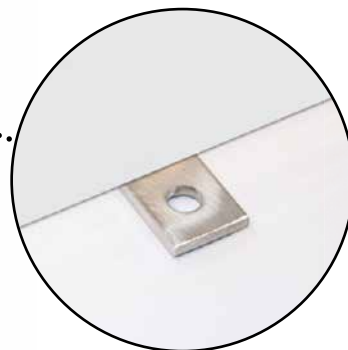

Powder coated in two colours  
RAL 7047 / 9010

# Ten Good Reasons to Specify or Install a Gorter Roof Hatch

The roof space of buildings are increasingly being used for mechanical appliances such as air conditioners, lift motor rooms and machine rooms, as well as roof terraces, roof gardens and emergency escape routes. This is why it is vital for any roof access solution to be high quality, durable, convenient to use, and above all; safe, to meet increasingly stringent safety standards.

» Gorter supplies safe roof access solutions which are aesthetically pleasing, easily integrated into any design, convenient, durable and will ultimately save money and contribute to the safe and long term operation of any commercial, industrial or residential building project.

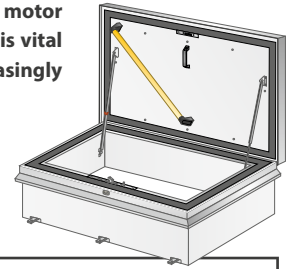

1

## Money Saving Roof Access

Gorter roof hatches offer safe and convenient access to any roof space. Gorter roof hatches offer a simple and money saving alternative to a vertical door construction for roof access. The Gorter range of roof hatches are aesthetically pleasing and unobtrusive. This allows easy integration into any design.



2

## SAFETY Features for the End-user

Gorter hatches are counterbalanced for one hand operation, and can be opened and closed with less than 5kg of force. The safety handrail provides a safe and sturdy handhold and the hold open arm ensures the lid cannot accidentally shut. The open lid also protects against any fall danger. Gorter products are designed with the safety of the end user at heart.



3

## A Complete Access Solution

Depending on the opening size needed, Gorter Roof Access Hatches can be supplied complete with a safety hook-on ladder, scissor stair or fixed step or rung ladder. All Gorter combinations are tested for safety and certified to comply with occupational health and safety standards.



4

## We Have Thought of the Architect

The Gorter website has standard drawings and specifications available on our wide range of access products. Gorter's experience staff can also provide advice, test reports, as well as safety approvals. This allows the architect to specify a Gorter product with confidence. Please contact us for custom drawings or specifications. [www.gortergroup.com](http://www.gortergroup.com)



5

## Less Mass, More Class

Because at Gorter many of our staff are from the building industry, we understand such a job is physically demanding. That is why many of our products are manufactured from aluminium, making it just as strong and durable but up to 3 times lighter than a similar product made from steel or stainless steel. This ensures a Gorter product is easy to install and handle.



6

## Easy Installation at Minimal Cost

Gorter products are supplied completely assembled. We have even predrilled mounting holes in the flange. Installation consists of simply placing the hatch over the roof opening, bolting it in place, and ensuring watertightness by flashing underneath the curb. All this can usually be done in the space of around 1 hour.



7

## High-quality insulation

The roof hatches are designed to be weather and wind-proof and are provided with high-quality insulation:  $U_w \leq 0,198 \text{ W/(m}^2\cdot\text{K)}$  for the entire roof hatch construction. Standard sound reduction: 26 dB.

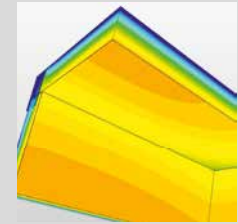

8

## Strong and Durable Construction

Gorter Roof Hatches are manufactured only from the strongest and highest quality materials. All metal used is anodized, zinc plated or galvanized and then powder coated. Roof hatches at least 1501 mm in length have a 3-point latch system. All materials are 100% recyclable.



9

## Fire Rating or Explosion Relief

Gorter Roof Hatches can also be supplied with added features such as fire rating (EL-120 as per AS1530-4) or a patented Explosion Release Control. Many optional features such as integration with alarm or fire systems, electrical operation, glazed lid, double doors or extra security features among many others are also available.



10

## 10-year warranty

A 10-year warranty applies to all roof hatches. There is a 1-year warranty for electrical control systems and staircases. The safety, performance, and construction of the roof hatch with (scissor) stairs or a ladder, are based on previously certified roof hatch models from Gorter.



Please visit our website, or contact our offices below for more information

